

# ELITE PLUS

## PV Module

ET-M672BH450WW/WB	450W
ET-M672BH445WW/WB	445W
ET-M672BH440WW/WB	440W
ET-M672BH435WW/WB	435W
ET-M672BH430WW/WB	430W



1500

### High Voltage

UL and IEC 1500V certified; lowers BOS costs and yields better LCOE



### High Efficiency

Higher module conversion efficiency benefit from half cell structure (low resistance characteristic).



### PID Resistance

Excellent Anti-PID performance guarantee limited power degradation for mass production.



### Low-light Performance

Advanced glass and cell surface textured design ensure excellent performance in low-light environment.



### Severe Weather Resilience

Certified to withstand: wind load (2400 Pascal) and snow load (5400 Pascal).



### Durability Against Extreme Environmental Conditions

High salt mist and ammonia resistance certified by TUV SUD.

\*6BB and MBB products can be provided upon request.

IEC 61215  
IEC 61730  
UL 61215  
UL 61730



ET SOLAR

support@etsolar.hk



M/ET-PD-EN-EU2020V3

## ELECTRICAL SPECIFICATIONS

Model Type	ET-M672BH450WW	ET-M672BH445WW	ET-M672BH440WW	ET-M672BH435WW	ET-M672BH430WW
	ET-M672BH450WB	ET-M672BH445WB	ET-M672BH440WB	ET-M672BH435WB	ET-M672BH430WB
Peak Power (Pmax)	450W	445W	440W	435W	430W
Module Efficiency	20.4%	20.2%	19.9%	19.7%	19.5%
Maximum Power Voltage (Vmp)	41.4V	41.2V	41.0V	40.8V	40.6V
Maximum Power Current (Imp)	10.88A	10.81A	10.74A	10.67A	10.60A
Open Circuit Voltage (Voc)	50.0V	49.8V	49.6V	49.4V	49.2V
Short Circuit Current (Isc)	11.47A	11.40A	11.33A	11.26A	11.19A
Power Tolerance	0~+4.99 W				
Operating Temperature	- 40 ~ + 85 C				
Maximum System Voltage	DC 1500V				
Nominal Operating Cell Temperature	45±2 C				

## ELECTRICAL SPECIFICATIONS (NOCT)

Model Type	ET-M672BH450WW	ET-M672BH445WW	ET-M672BH440WW	ET-M672BH435WW	ET-M672BH430WW
	ET-M672BH450WB	ET-M672BH445WB	ET-M672BH440WB	ET-M672BH435WB	ET-M672BH430WB
Peak Power (Pmax)	338W	334W	330W	326W	323W
Maximum Power Voltage (Vmp)	37.96V	37.90V	37.84V	37.78V	37.72V
Maximum Power Current (Imp)	8.89A	8.81A	8.72A	8.63A	8.56A
Open Circuit Voltage (Voc)	46.7V	46.5V	46.3V	46.1V	45.9V
Short Circuit Current (Isc)	9.56A	9.48A	9.40A	9.32A	9.24A

## MECHANICAL SPECIFICATIONS

Cell Type	166mm x 83mm
Number of Cells	144 half-cells (6×24)
Weight	24 kg
Dimension	2109×1046×35mm
Front Glass	3.2mm, Anti-Reflection Coating, High Transmission, Low Iron, Tempered Glass
Junction Box	IP67 rated
Frame	Anodized Aluminium Alloy
Output cables	4mm <sup>2</sup> ; Portrait:255mm(+)/355mm(-) Or customized

## TEMPERATURE COEFFICIENT

Temp. Coeff. of Isc (TK Isc)	0.048% /°C
Temp. Coeff. of Voc (TK Voc)	-0.290%/°C
Temp. Coeff. of Pmax (TK Pmax)	-0.350%/°C

## PACKING MANNER

Container	40' HQ
Pieces per Pallet	31
Pieces per Container	726

## PHYSICAL CHARACTERISTICS

Unit:mm (inch)

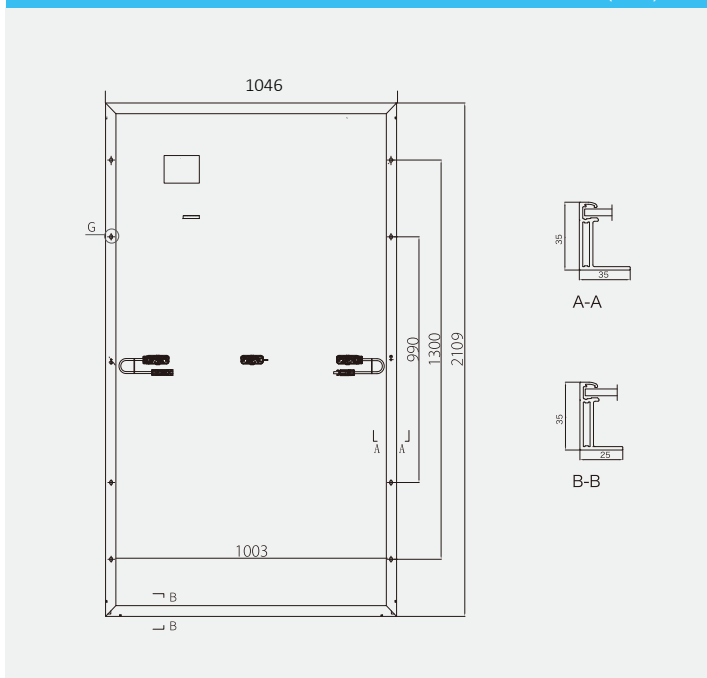

## ELECTRICAL CHARACTERISTICS

### Current-Voltage Curves (430W)

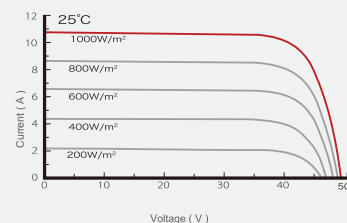

### Power-Voltage Curves (430W)

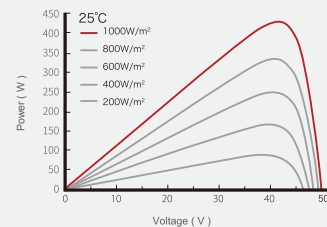

**Note:** the specifications are obtained under the Standard Test Conditions (STCs): 1000 W/m<sup>2</sup> solar irradiance, 1.5 Air Mass, and cell temperature of 25°C. The NOCT is obtained under the Test Conditions: 800 W/m<sup>2</sup>, 20°C ambient temperature, 1m/s wind speed, AM 1.5 spectrum.

Please contact [support@etsolar.hk](mailto:support@etsolar.hk) for technical support. The actual transactions will be subject to the contracts. This parameters is for reference only and it is not a part of the contracts. The specifications are subject to change without prior notice.